

Differential Pressure Regulator P₁: max. 414 bar, P₂: 0-103 bar

RH44

Description	The dome loaded, spring biased regulator is designed for pressure tracking applications to maintain a constant differential pressure. Venting allows for pressure tracking increases and decreases.		
Media	compressed air or gases according to the selected material		
Supply pressure	max. 414 bar	Outlet pressure	max. 103 bar
Exhaust	tapped exhaust 1/4" NPT	Control port	1/8" NPT
Adjustment	hexagonal screw for spring tension	Leakage	bubble-tight
Gauge port	not available	Mounting position	any
Temperature range	-26 °C to 74 °C / -14 °F to 165 °F		
Material	Body:	brass, optionally stainless steel 302	
	Valve seat and gasket:	CTFE, Vespel	
	O-Rings:	FKM	

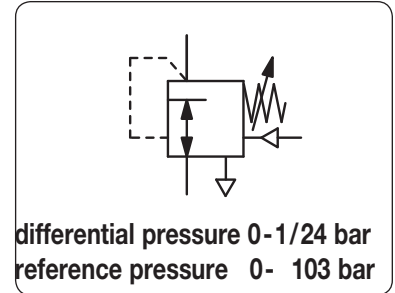

Dimensions			K _v -value (m³/h)	Flow rate l/min*1	Connection thread NPT	Differential pressure range bar	Order number
A mm	B mm	C mm					

Differential pressure regulator							
P ₁ max: 414 bar, P _A max: 103 bar, brass relieving, P ₂ : 0 ... 103 bar, FKM / CTFE							
76	212	46	0.7	10000	1/2" NPT	0... 1 bar	RH44-04A
						0... 7 bar	RH44-04B
						0... 14 bar	RH44-04C
						0... 24 bar	RH44-04D
76	212	46	2.0	21000	3/4" NPT	0... 1 bar	RH44-06A
						0... 7 bar	RH44-06B
						0... 14 bar	RH44-06C
						0... 24 bar	RH44-06D



RH44



Special options, add the appropriate letter

stainless steel body

RH44-0..S

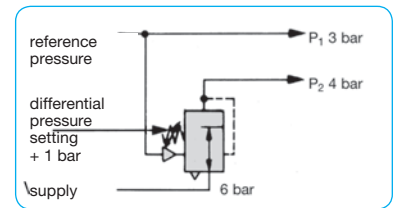

Example: differential pressure constant 1 bar

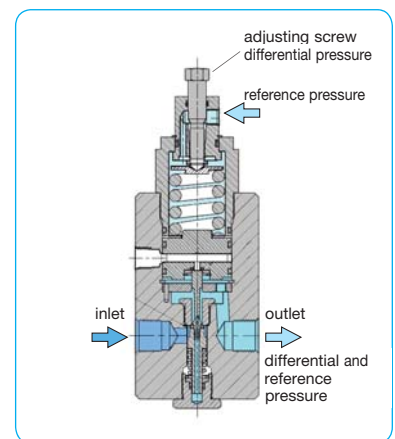

cross-section

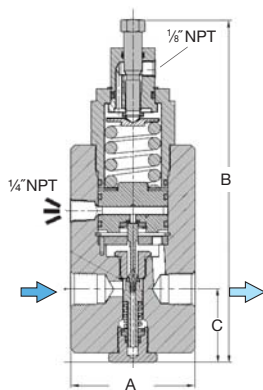

RH44

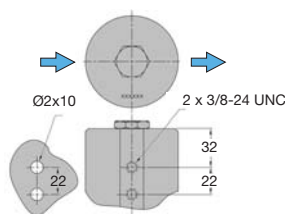

panel-mounting

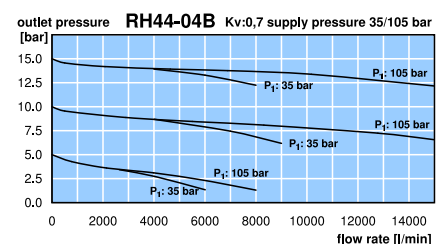

*1 bei P₁ = 105 bar, P₂ = 15 bar and Δp = 1 bar

Stainless steel version: see chapter for stainless steel devices

PDF CAD
www.aircom.net



Order example:
RH44-04A